



SWIMTRAINER



SWIM ACADEMY
FREDS

Europas **beste** und **qualitätsgeprüfte** Hotels für **Familienurlaub** mit Betreuung
Europe's best, quality-inspected family holiday hotels offering child care



Spielen im Urlaub – Schwimmen lernen mit FRED'S SWIM ACADEMY
Holiday fun and games - learn to swim with FRED'S SWIM ACADEMY



D A S O R I G I N A L
KinderHotels®
☺☺☺☺☺
www.kinderhotels.com



1



**WARNUNG! WARNING! ATENCION! AVERTISSEMENT! ATTENTION! ATENÇÃO!
ПРЕДУПРЕЖДЕНИЕ! OPOZORILO! UWAGA! DÈMESIO! WAARSCHUWINGEN!
ADVARSEL! ! تحذير! VÝSTRAHA! VAROVANÍ! 경고! 警告! ΠΡΟΣΟΧΗ! UYARI!**

1a



1b

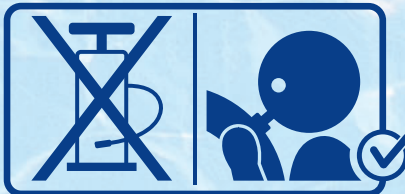

1c

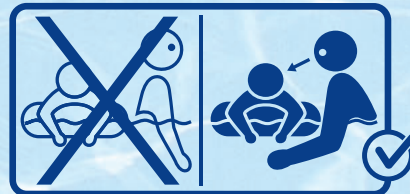

1d



1e

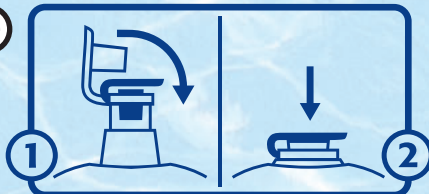

1f

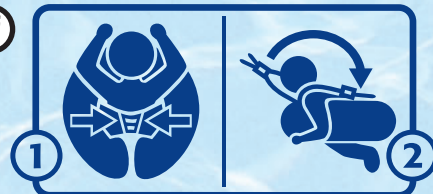

1g

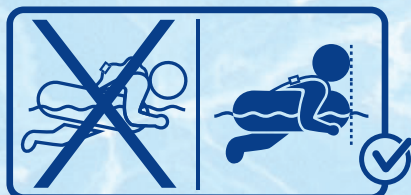

1h

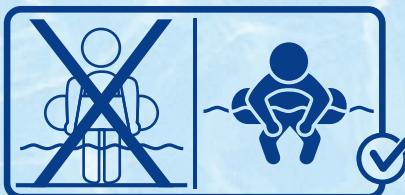

1i

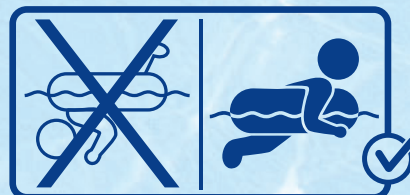

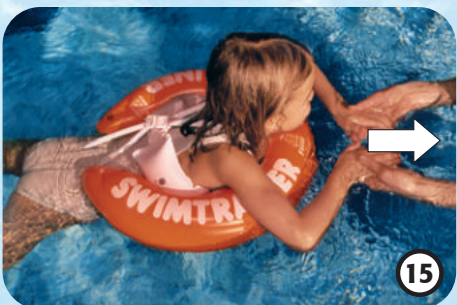
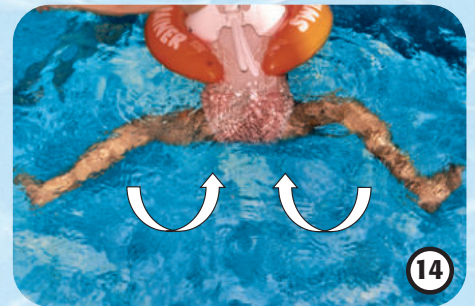
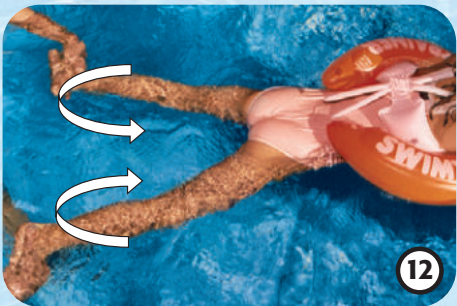
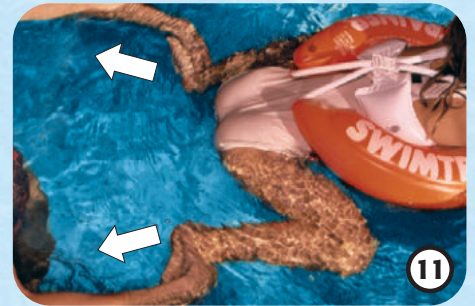







www.swimtrainer.com



Dear parents,

Thank you for deciding to buy our SWIMTRAINER „Classic“. Our SWIMTRAINER „Classic“ is a swimming aid specially designed in our swimming schools. It was created according to the maxim „a lot of fun with certainty“. In

the first part we will explain how to use the SWIMTRAINER „Classic“. The second part then deals with instructions on learning to swim. You yourself can help your child develop from a non-swimmer to being able to swim non-stop for quite some time. We wish you and your child a lot of fun and success with our patented swimming aid. Yours FRED'S SWIM ACADEMY

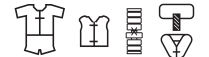
 ... kg ... lbs	EN 13138-1: 2021		
	red 6 – 18 kg 13 – 40 lbs	orange 15 – 30 kg 33 – 65 lbs	yellow 20 – 36 kg 45 – 80 lbs
			
			
	✓	✓	✓
	⚠	⚠	⚠

Caution informations

1. Read instruction first!
- 1a. Does not prevent drowning!
- 1b. Inflate the air-chambers by mouth!
- 1c. Use only under constant supervision!
- 1d. Inflate all airchambers always fully!
- 1e. Close and depress valves!
- 1f. See points 3-6
- 1g.+1i. Swimming Position
- 1h. Do not use in shallow water

Note: Please be reminded the wearer of this swimming aid must be under constant, competent supervision and the supervisor should be within arm's reach of the wearer!

Learning the leg movement in the Orange Ring

Move behind your child and grasp its feet in such a way that your thumbs are on the outside of its feet/soles. Make sure the toes are pointing outwards so that the pushing-off force can be used effectively. First bend the legs, then stretch the legs backwards at an angle, close the legs and then bend them again. If breaststroke is carried out technically correctly, the legs are the „motor“. For this reason, this pattern of movement must be repeated very often.

Practicing the leg movement

Your child should initially only practice this leg movement, since this movement forms the basis for swimming without a great deal of effort. Make sure from the edge of the pool that the toes are pointing outwards during the pushing-off movement. Show your child this leg movement repeatedly at regular intervals. Your child should repeat this movement until it has become automatic. It is not until this has happened that your child should learn the arm movement.

Learning the arm movement

Stand in front of your child in the water. The palms of your hands are facing upwards. Your child should place its hands with closed stretched fingers on your hands. You start with your child's hand touching near the ring, stretch the arms out, move them outwards in a semi-circular movement, repeat the movement. Make sure your child's fingers remain stretched during the whole movement. To do this hold your child's hand exactly as illustrated.

Technical description

- | | |
|-------------------|------------------------|
| 2a. Inner chamber | 2e. Body fitting parts |
| 2b. Outer chamber | 2f. Quick fastener |
| 2c. Stomach part | 2g. Quick fastener |
| 2d. Safety belt | 2h. Valves |

Inflating the SWIMTRAINER „Classic“

First inflate the white air chambers. Then inflate first the inner (2a) and then the outer chamber (2b) of the ring. Do not forget to close and depress the valves. The SWIMTRAINER „Classic“ has been inflated correctly if there are no folds visible on the ring. The ring is adjusted to the size of the child's body by letting air out at the two body fitting parts.

Putting the SWIMTRAINER on babies

The inflated ring is put on and taken off out of the water. Lay your baby on its stomach in the ring. The baby's chin is resting on the frog logo (1g) (in the case of very young children, make sure that they do not tip over due to the top-heavy center of gravity), the other two ends of the ring close over the bottom. Close the fastener of the two body fitting parts (2f). Now pull the safety belt over the head, adjust the length of the belt and then close this fastener (2g). Undress the product in reverse order.

Putting the SWIMTRAINER on children

The inflated ring is put on and taken off standing up. Place the safety belt over the child's head from the front. Move to behind your child. The child must stretch its arms up-wards. Pull the two body fitting parts past the side of the child and close the fastener

Coordinating arm and leg movement

To get the best overall view, leave the pool. As soon as you notice that your child wants to stretch its legs, you call „Forwards“ or „Stretch“ – at first every time the movement is to be repeated. This is the easiest way for your child to learn coordination. This exercise should be repeated very often. We then recommend you switching to the yellow ring, this offers less upward movement and more freedom of movement while retaining stability.

Transition to free swimming

Your child should practice the arm and leg movements as long as it takes to strengthen the movements. **It is important that movements and breathing are both steady.**

Manufacturer's information

The valves of the SWIMTRAINER „Classic“ comply with European and Australian safety standards. At appropriate inner pressure the return flap prevents air escaping suddenly from the chamber. The return flap can lose its exact shape during packaging and transport. This fault is automatically corrected once the swimming aid has been used several times. Clean with water only. Check seams regularly for leaks by submerging the ring under water checking for escaping bubbles. Please store dry and deflated. Inflate the air-chambers by mouth. In case of loss of air and/or damage do not longer use the product. Do not use in shallow water. Do not bite into the product and do not chew it – danger of suffocation. For the transport a dry and air-permeable bag is recommended.

The SWIMTRAINER „Classic“ has not been designed for jumping into the water.

(2f). The child's chin should be on level with the frog logo (1g). Now pull the safety belt over the head, adjust the length of the belt and then close this fastener (2g). Undress the product in reverse order.

Babies' innate frog reflex

Babies are born with the so-called frog reflex which enables them to move independently in the water in our SWIMTRAINER „Classic“ red. This reflex is usually lost while babies are learning to walk.

With the SWIMTRAINER „Classic“ you can help your child not to lose this reflex or to learn it again and remember it. This will help your child to learn breaststroke more easily later.

Leg movement in babies/toddlers

Move behind your child and grasp its feet. Repeatedly bend and stretch your child's relaxed legs. Make sure the toes are pointing outwards. Every time you stretch/push off, call „frog“. Practice this again and again in between periods of play. Your child will soon understand: „frog“ = push off. Later your child should then carry out these pushing-off movements in the water itself whenever it hears the word „frog“.

Suggestions for games with babies

Tempt your baby with a toy so that it carries out the frog reflex all by itself. Let your baby reach the toy and repeat the exercise. Your baby will quickly learn to consciously use these leg movements. You can e. g. pour water onto your baby's back in the water using a small watering can. This stimulus on the baby's very sensitive back causes most babies to kick their feet, thus moving forward.

Date of Manufacture

 = produced: month/year.

Warranty/Lifetime

The warranty-period is 6 months, it begins with the date of purchase. The life span is 5 years, starting with the date of manufacture. Only those faults will be accepted that can be proved to have been caused by faulty material or production. The right of replacement is inapplicable if the fault has been caused by incorrect handling, ignoring the instructions for use or willful damage. If the complaint is unfounded, the manufacturer has the right to charge a reasonable sum for inspection and dispatch.

Non-entitlement to warranty performance

Due to the small volume of air in the stomach part the air can escape if the valve is open. This is not a production fault and can thus not be the subject of complaint. If a seam is proved to have torn due to the child jumping into the water the warranty claim is invalid. Production tolerances can lead to the fastener not always closing immediately. In this case, press the tongue on the fastener upwards until you hear the fastener click into place.

Certification authorities

- The packaging complies with the environmental guidelines of the „Green spot“.
- Name of the directive: Regulation (EU) 2016/425 of the European Parliament. The product complies with DIN EN 13138-1: 2021 and AS/NZS 1900-2014 Flotation aids for familiarization and swimming tuition
- Testing authority: TÜV SÜD Danmark ApS
Strandvejen 125, 2900 Hellerup
- Declaration of conformity: www.swimtrainer.com/EU-konform

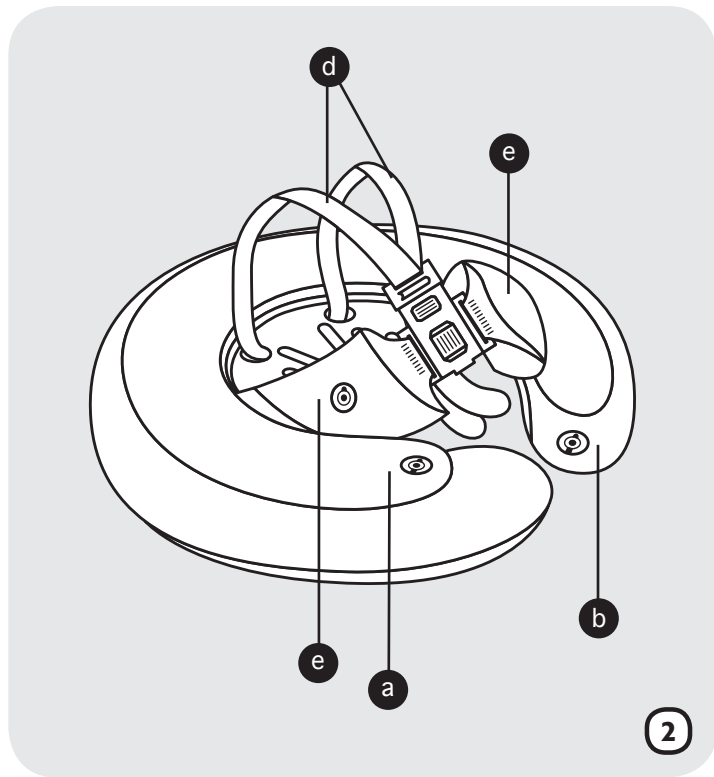
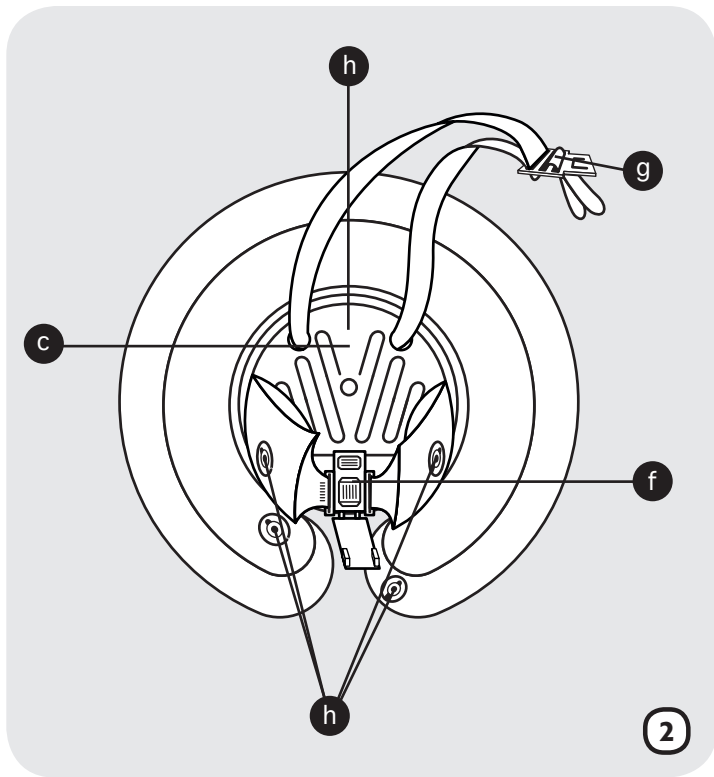



Herausgeber/Publisher

Germany – Head Office
FREDS SWIM ACADEMY GmbH

Josef-Kronthaler-Straße 14
86157 Augsburg

☎ +49 821 579242
office@swimtrainer.com

Die Kontaktdetails unserer Importeure finden Sie unter:
You will find the contact-details of our importers here:
Aqui encontrara mayor informacion acerca de nuestros importadores:

www.freds-swim-academy.com/kontakt

